



Gamesman

GPB430 Push Button Product Specification

Issue 03: Date 11.12.2015



Disclaimer:

The information provided within this product specification is intended only to make the reader aware of the product's technical data and its use thereof. As such, Gamesman Ltd shall not be held liable for any loss or damage to the assembly or component within, arising from its misuse or from the unintended use of information or particulars included within, or any omission from, this document.

Design and specifications are subject to change without notice.

Failure to observe the interface requirements specified in this document may result in damage to the electronics and resultant performance characteristics of the product.

1. Product Dimensions

a) General Dimensions

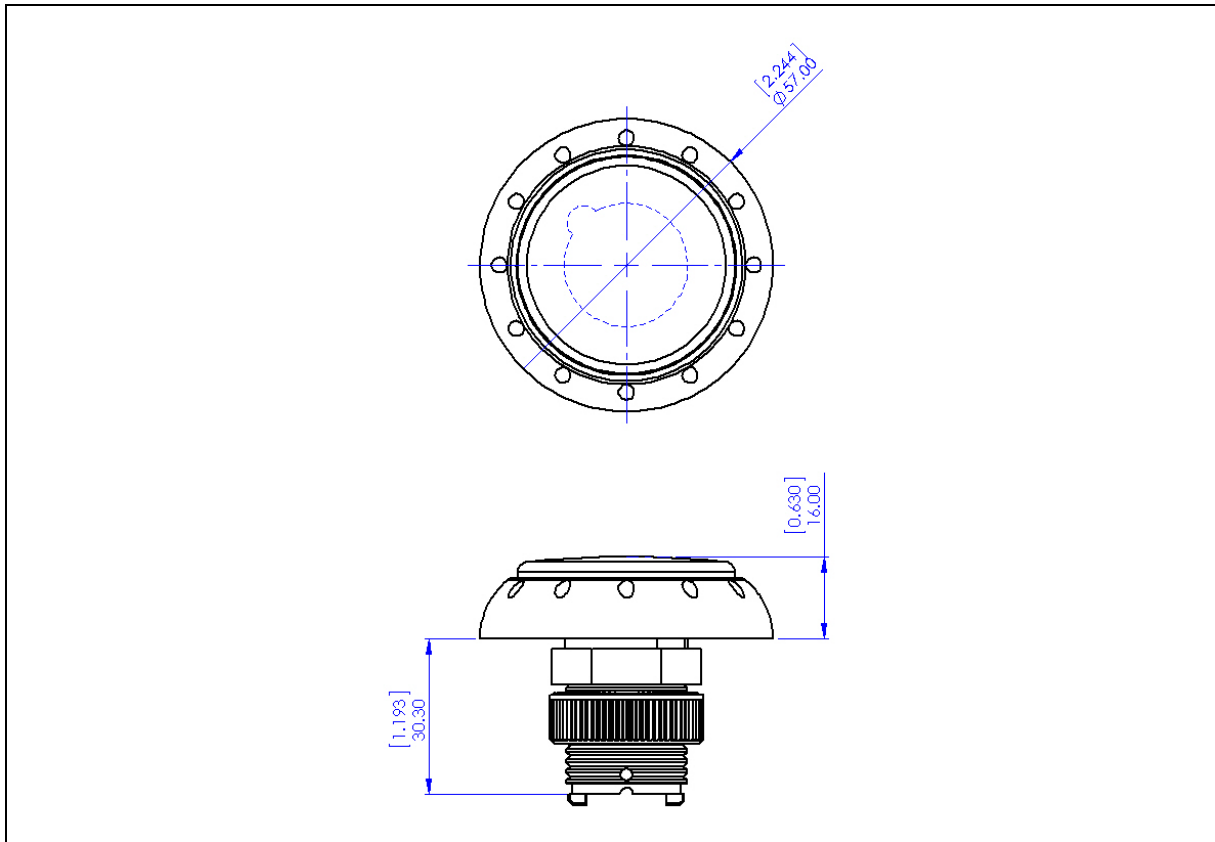

b) Insert Dimensions

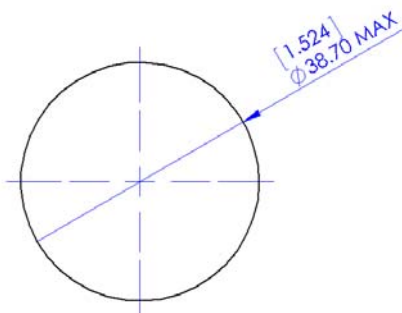

Insert Material – Acetate sheet or similar.
 Insert Thickness – 0.2mm [0.008"] Minimum – 0.25mm [0.010"] Maximum
 Circular insert should be adhesive backed.

c) Panel Cut out Details

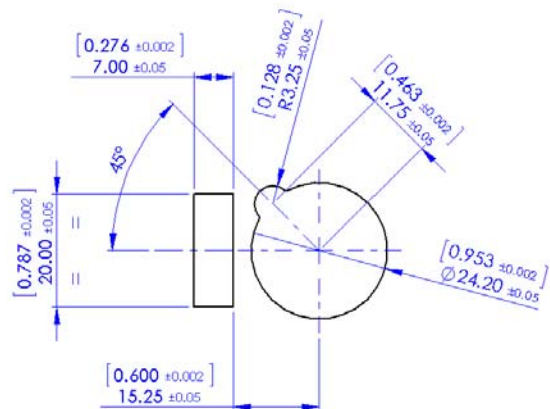

Panel thickness with standard nut: 1.50mm
 Minimum - 12.0mm [0.472"] Maximum
 Panel thickness with Long Nut: 4.00mm [0.157"] Maximum.
 This panel cut out shown is for use with Disco PCBA, if the PCBA is not used then omit the rectangular profile on the cut out.
 See mounting orientation details Page 6

2. Product Identification

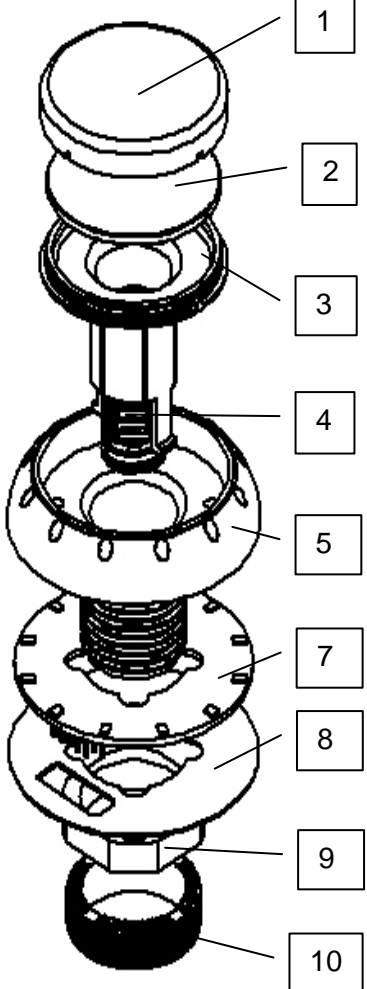
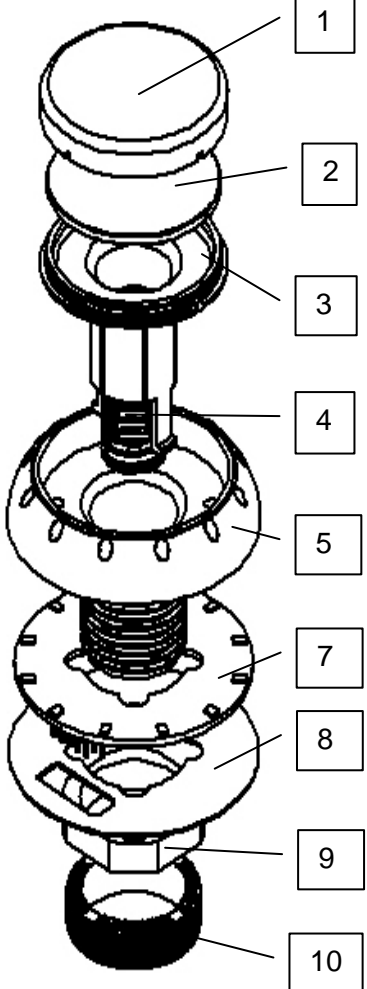
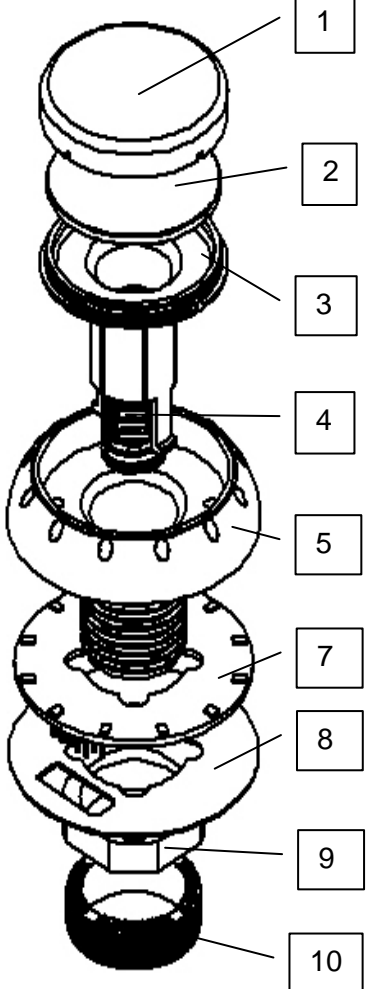
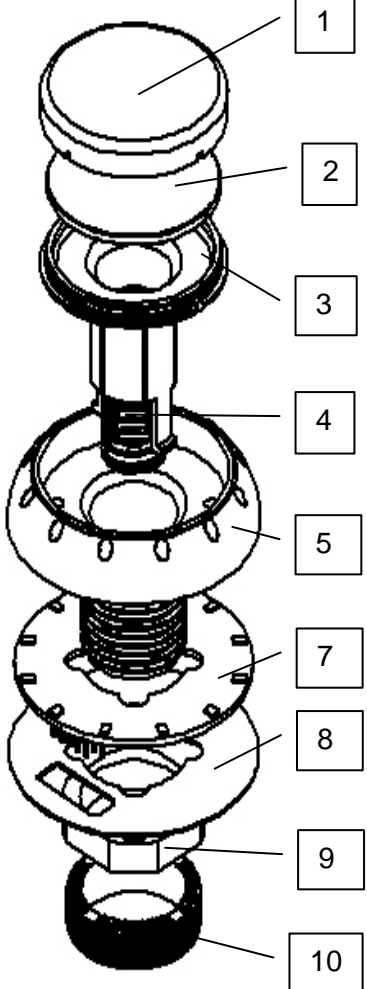
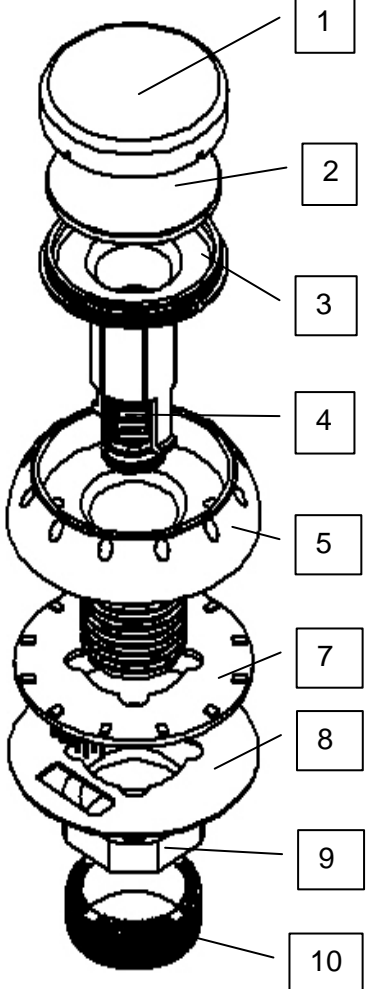
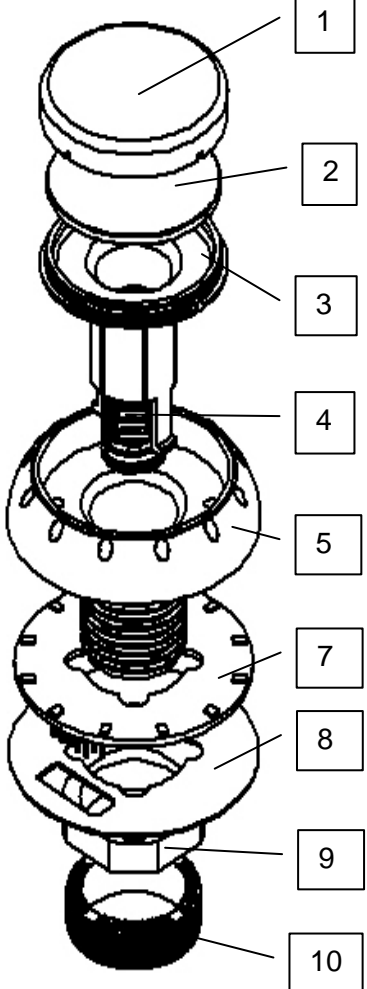
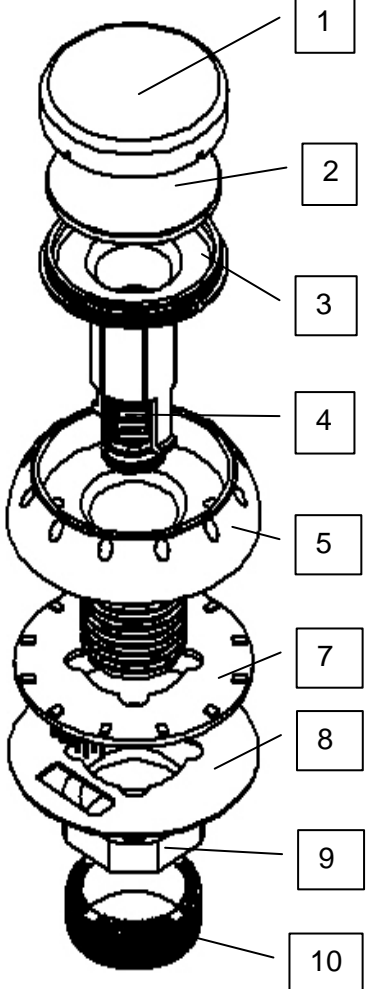
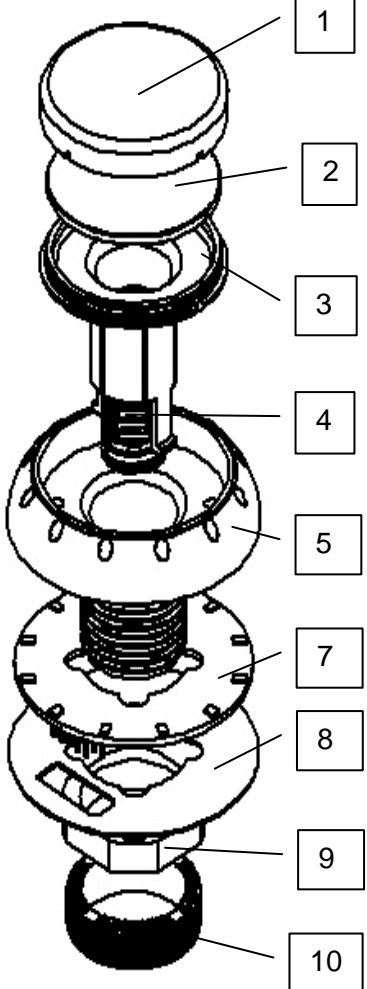
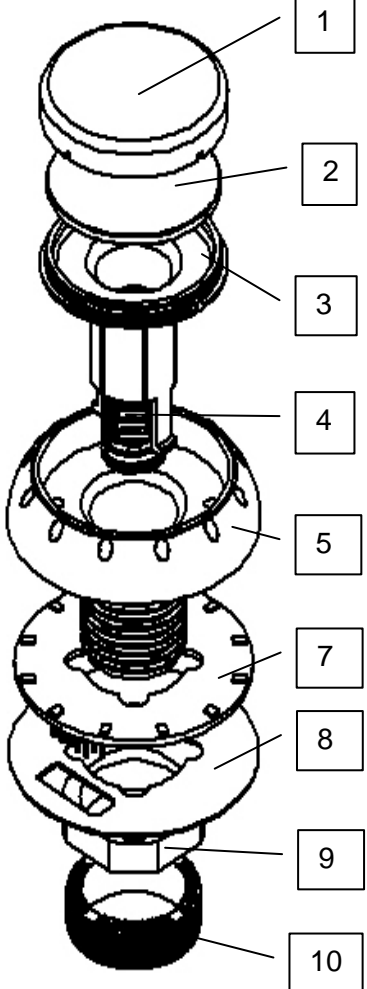







	No.	Part Number	Description	Material	UL94 Rating
 <p>1</p>	1	GMP02606 Or G3-302	Lens	Polycarbonate See Note 1.	V2
 <p>2</p>	2	G4-454 Or GMP01059	Legend Plate	Opal Polycarbonate	V2
 <p>3</p>	3	G3-303	Plunger	Opal POM	HB
 <p>4</p>	4	G4-330	Spring	Spring Steel	N/A
 <p>5</p>	5	Various	Bezel	Polycarbonate See Note 1.	V2
 <p>7</p>	6	G4-832	Spacer Void - Fitted if Disco PCBA not required Not Shown	Clear Polycarbonate	V2
 <p>8</p>	7	Various	PCBA – See List for options	Various	N/A
 <p>9</p>	8	G4-452	Gasket – For use with PCBA	Black PVC	N/A
 <p>10</p>	9	G4-794	Washer Std.	ABS	HB
	10	G4-145	Std. Nut	ABS	HB

Note 1. Component available in various colours/colour combinations, see specification sheet for the options. Minimum Order Quantities may apply.

3. Product Compatibility – [Specification options GPB430 Spec Sheet.xls](#)



a) Switch Systems

<p>System S</p>		
<p>System JA – Standard Circuit</p>		
<p>System JC – NO Diode Circuit</p>		
<p>System RGB / BX The below LED and Lamp Solutions do not apply to this switch system.</p>		

b) LED Solutions



Volts	Colour
12v	White
12v	Blue
6.3v	White
3.3v	White

c) Lamp Solutions – T-3¼ - 10mm Lead Free Wedge Base Lamps

Volts	Current (mA)	Light Output (Lm)	Life (Hrs)
12v 0.1A	100	5.0	5,000
12v 2CP	200	22.6	1,000
24v 2CP	95	13	5,000

*All values are nominal

d) Disco PCBA Options

LED Colours	Circuit	Part Number	Spec Sheet Code
Red and Green	Common Anode	G3-353	A
Red and Green	Common Cathode	G3-729	C
Red and Blue	Common Anode	G3-779	D
Red and Blue	Common Cathode	G4-1514	E
Red and White	Common Anode	0927-G01537	F

VIEWED FROM TOP

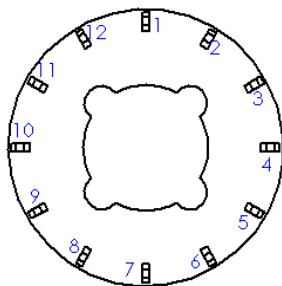

LED SIDE

VIEWED FROM BOTTOM

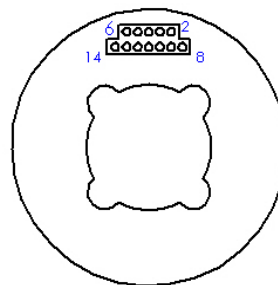

CONNECTOR SIDE

Common Anode

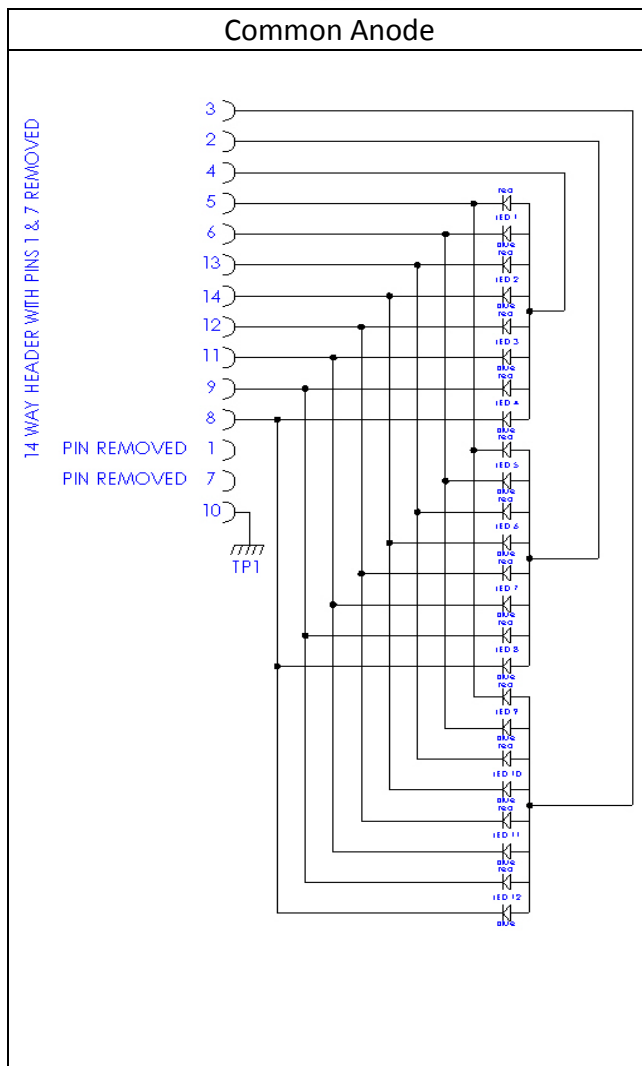

Common Cathode

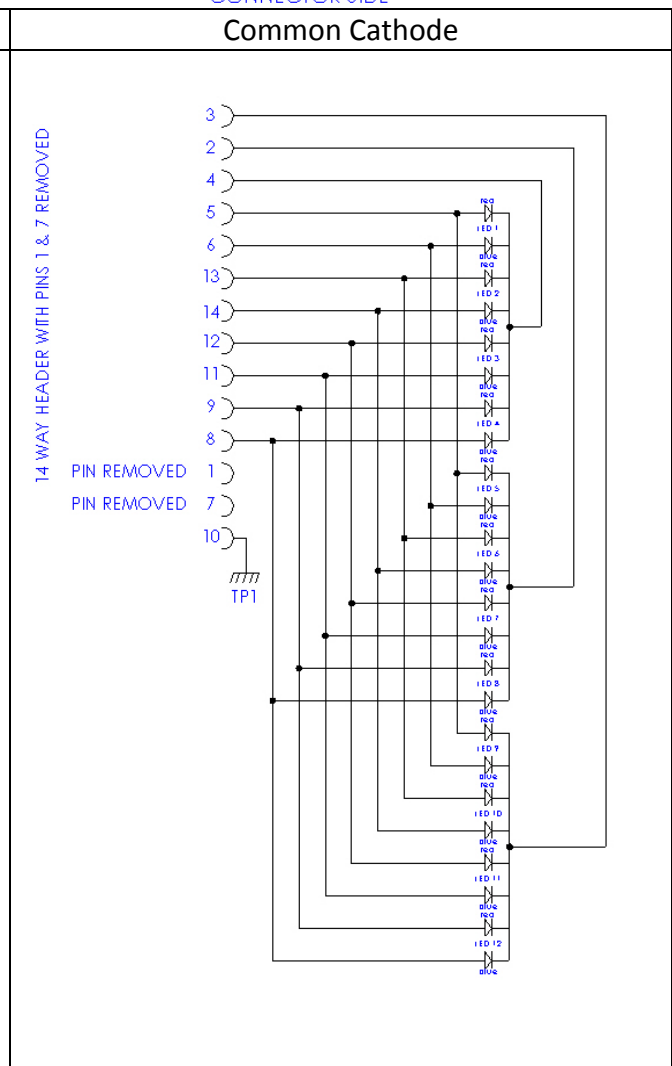

e) Disco PCBA Options continued : Connection Details for PCBA:

Gamesman recommends the following connector for connection to the 'Disco' PCBA

Dual row crimp housing 2652 Series 2.54 x 2.54mm (0.100 x 0.100")

With polarisation – 2652-2141

Without polarisation – 2652-3141

Accepts crimps 2653 and 2663

4. Mounting Orientation Details

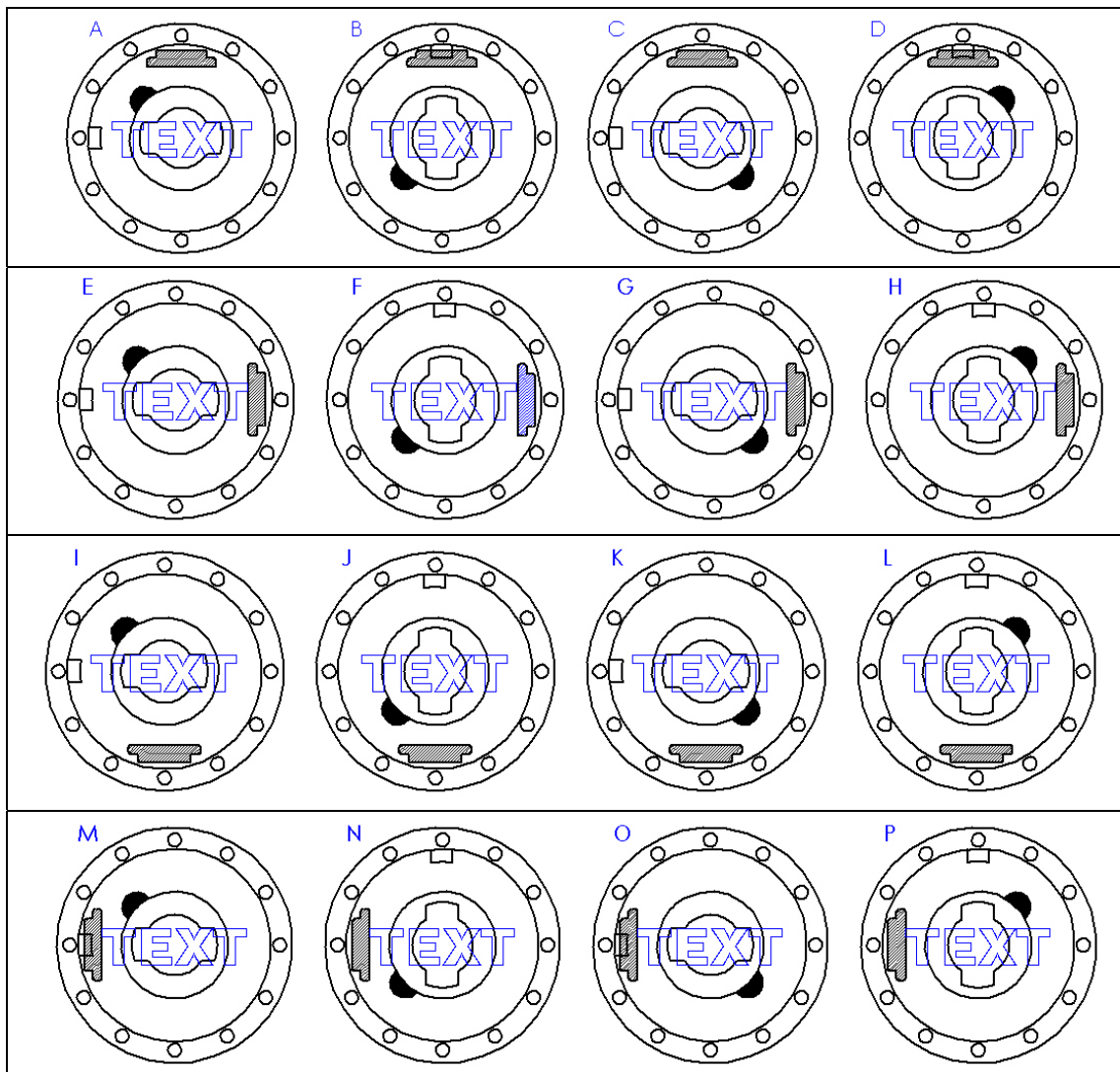

Button viewed from front of button.

5. Accessories

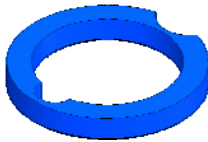
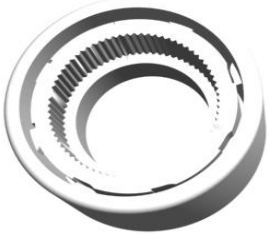
<p>For an alternative long nut for quick release, please order Gamesman Part Number G3-589. If you would prefer the long nut with your push button, please specify in the comment section of the specification sheet.</p>	
<p>For an alternative thin washer, for use with thicker panels, please order Gamesman Part Number G4-1119, or specify in comment section of the specification sheet.</p>	
<p>Nut Runner Tool for tightening to the recommended torque – please order Gamesman Part Number G3-499.</p>	

6. Specification Sheet

[Specification options GPB430 Spec Sheet.xls](#)



GAMESMAN LTD
CROMPTON FIELDS, CROMPTON WAY, CRAWLEY, WEST SUSSEX, RH10 9QB
TEL: +44 (0) 1293 418888 FAX: +44 (0) 1293 418880

REGISTERED IN ENGLAND No. 3027138

Website: www.gamesman.co.uk

E-mail: sales@gamesman.co.uk