



Gamesman

# GPB551 Push Button Product Specification

Issue 02: Date 05.01.2021



Disclaimer:

The information provided within this product specification is intended only to make the reader aware of the product's technical data and its use thereof. As such, Gamesman Ltd shall not be held liable for any loss or damage to the assembly or component within, arising from its misuse or from the unintended use of information or particulars included within, or any omission from, this document.

Design and specifications are subject to change without notice.

Failure to observe the interface requirements specified in this document may result in damage to the electronics and resultant performance characteristics of the product.

1. Product Dimensions

a) General Dimensions

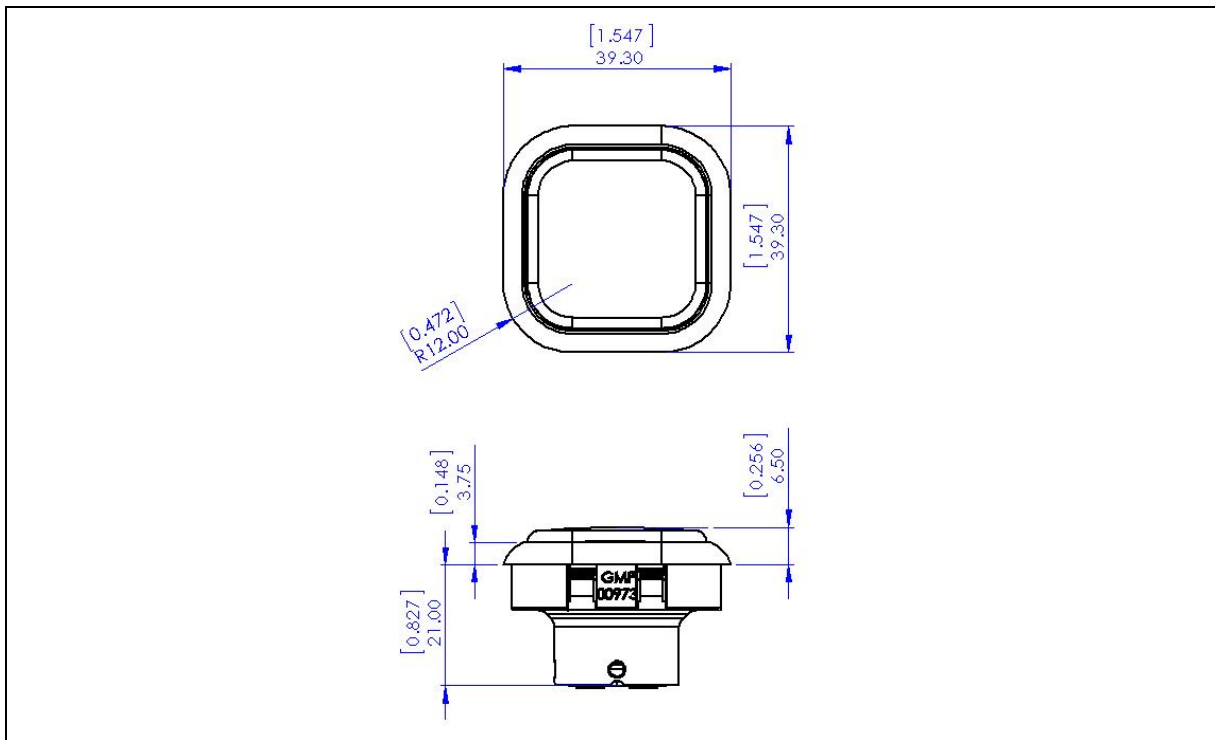

b) Insert Dimensions

c) Panel Cut out Details

<p>Technical drawing of the insert showing a square with rounded corners. Dimensions include a width of [1.063] (27.00 MAX) and a height of [1.063] (27.00 MAX). A chamfered edge is dimensioned as [0.236] (R6.00 MAX).</p>	<p>Technical drawing of the panel cut out showing a square with rounded corners. Dimensions include a width of [1.433 ±0.002] (36.40 ±0.05) and a height of [1.433 ±0.002] (36.40 ±0.05). A chamfered edge is dimensioned as [0.411 ±0.002] (R10.45 ±0.05).</p>
<p>Insert Material – Acetate sheet or similar.            Insert Thickness – 0.2mm [0.008"] Minimum – 0.25mm [0.010"] Maximum</p>	<p>Panel thickness: 1.50mm [0.059"] Minimum – 1.80mm [0.071"] Maximum</p> <p>Push buttons are snap fit to panel at the stated thickness. Should you need the button to fit into a thicker panel, please refer to Nut Options section in Accessories.</p>

## 2. Product Identification

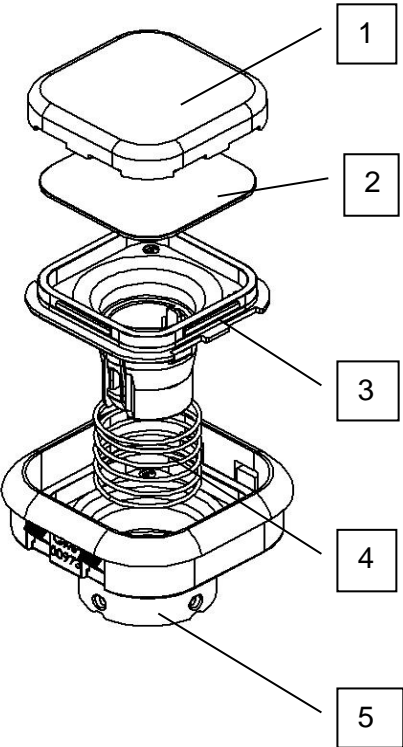
	No.	Part Number	Description	Material	UL94 Rating
	1	GMP00975	Lens	Polycarbonate See Note 1.	V2
	2	GMP00976	Legend Plate	Opal Polycarbonate	V2
	3	GMP00974	Plunger	White ABS/PC	V2
	4	G4-950	Standard Spring See Note 2.	Spring Steel	N/A
	5	Various	Bezel	Polycarbonate See Note 1.	V2

Note 1. Part is available in various colours/colour combinations, see specification sheet for the options. Minimum Order Quantities may apply.

Note 2. All push buttons are supplied as standard with a light spring.

### 3. Product Compatibility

#### a) Switch Systems

<a href="#">System Z</a>	
<a href="#">System Y</a>	
<a href="#">System U2</a>	
<a href="#">System U1</a>	
<a href="#">System W</a>	
<a href="#">System WA</a>	
<a href="#">System WB</a>	

#### b) [LED Solutions](#)

Please refer to the link for the latest LED Capsules supported by the switch systems listed above.

#### c) [Lamp Solutions – T-1 ½ - 5mm Lead Free Wedge Base Lamps](#)

Please refer to the link for the Lamps supported by the switch systems listed above.

4. Accessories

a) Tool

Extraction Tool for Button - Order Part Number GFP01448

5. Specification Sheet

Click the link below to complete a specification sheet of your requirements. If you have any questions regarding your options that are not covered in this document, please contact our sales team.

[GPB551.xls](#)

Packaging

Standard Packaging format for these buttons:

Lens & Legend Packed Separately in Bulk  
Switch Connection System Assembled to the Button  
Button Assembly Packed in Trays

For any deviations from this please refer to specification sheet.

Space Models

3D CAD models are available on request, please contact our Sales team.



# Gamesman

GAMESMAN LTD  
CROMPTON FIELDS, CROMPTON WAY, CRAWLEY, WEST SUSSEX, RH10 9QB  
TEL: +44 (0) 1293 418888 FAX: +44 (0) 1293 418880

**REGISTERED IN ENGLAND No. 3027138**

Website: [www.gamesman.co.uk](http://www.gamesman.co.uk)

E-mail: [sales@gamesman.co.uk](mailto:sales@gamesman.co.uk)